

The Elementary Woodshop

Applied Design, Skills and Technologies

Reference Guide for Teachers

LOGGING TRUCK

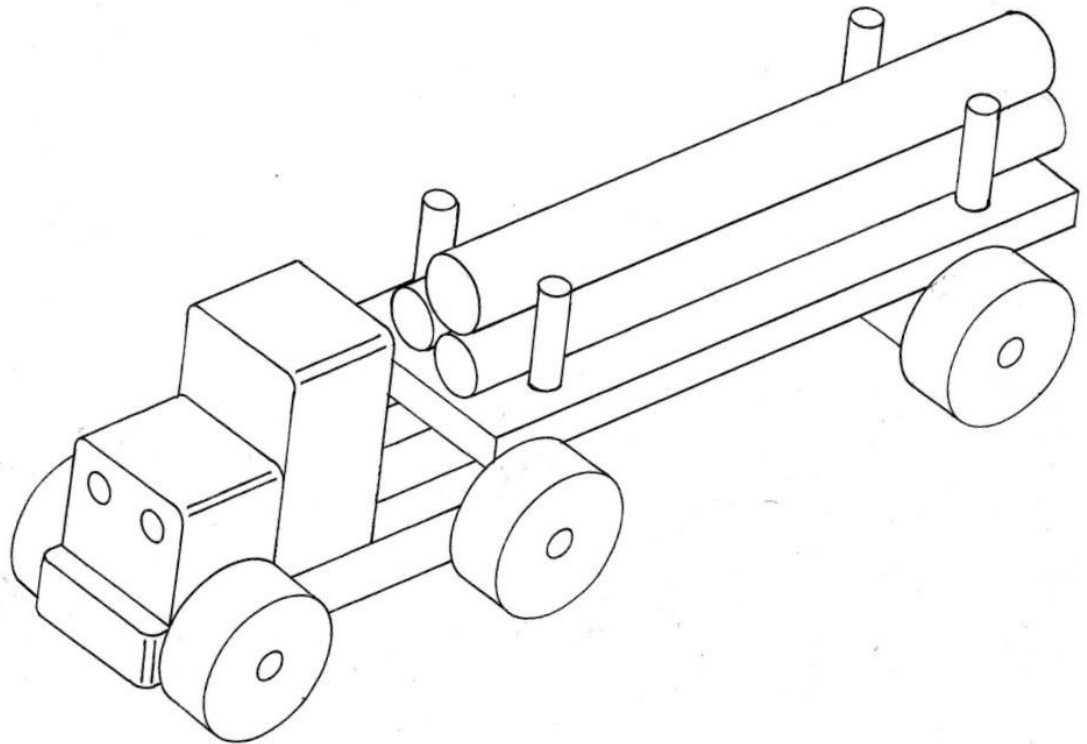

Recommended Reading Prior to Beginning Workbook and Assembly

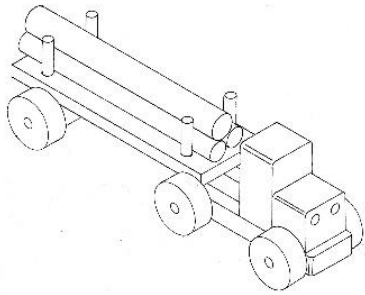

Logging Truck Reference Guide for Teachers

For a successful experience in your classroom it is recommended that you work through the accompanying Workbook and this Reference Guide prior to presenting the project to students.

As you work through the Workbook, it would be beneficial to assemble the woodwork project so you are better equipped to teach the assembly to your students. You may temporarily hold the wood pieces together using masking tape rather than glue which is required for permanent assembly with this woodwork project. The recommended drying time for wood glue is a minimum of 30 minutes.

A hammer is required for this project. A clamp or a vise and a hacksaw may be used to cut small branches for logs. As wood may splinter it is advisable to handle wood with care and have tweezers available in case of slivers.

Logging Truck Reference Guide for Teachers

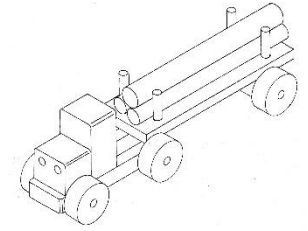

Section 2 Design

Page 3

1. **1/40**

Page 6

Optional Design Challenge Lesson Enhancement - to be undertaken only after assembly of Logging Truck (see page 7 of Teacher's Reference Guide).

Section 3 Hydraulics

Page 10

NOTE TO TEACHER: Using the syringes and plastic tube provided, demonstrate hydraulic principles. Fill one syringe with water; for visual effect add a drop of food colouring to the water.

Page 12

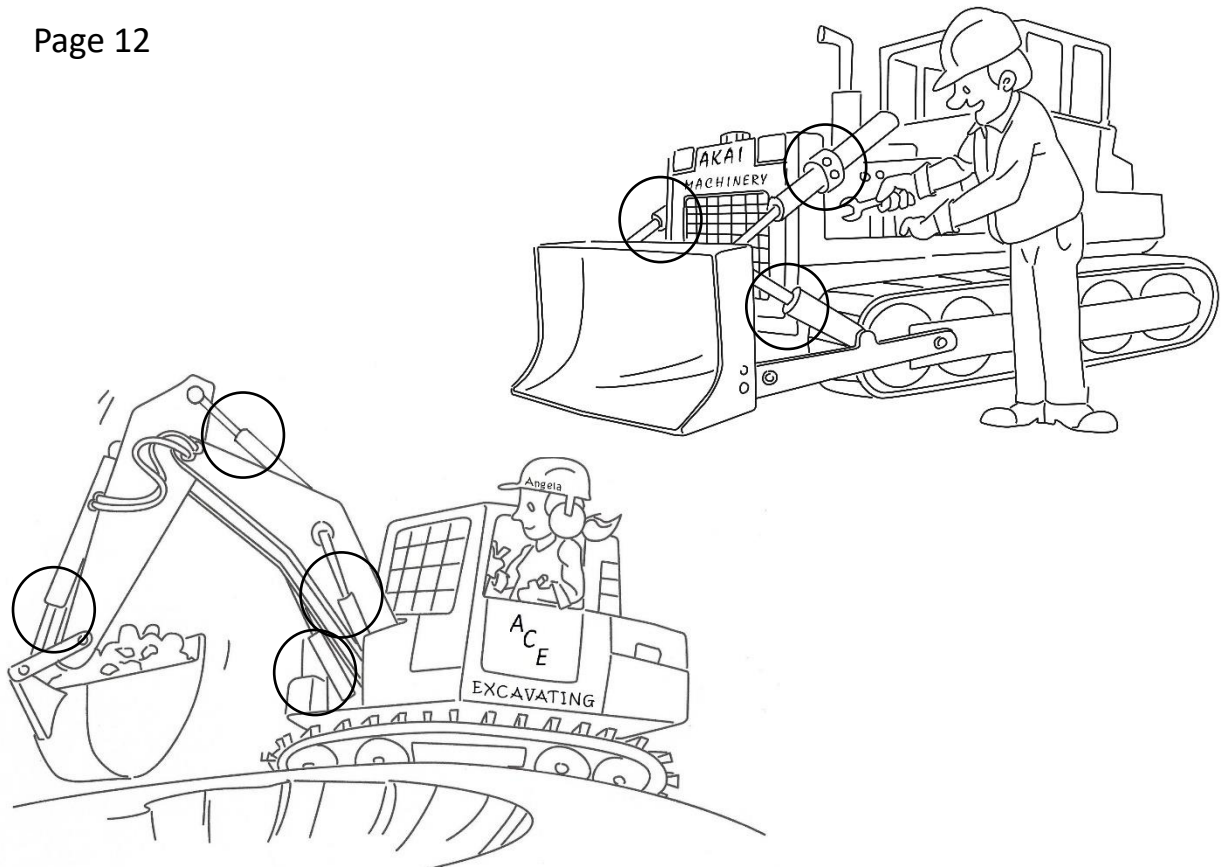

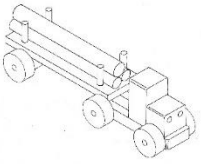

Logging Truck Reference Guide for Teachers

Section 4 Technical Drawing Pre-Assembly

Page 17

***NOTE TO TEACHER** - *distribute logging truck parts to students.*

Section 5 Math

Page 22 - 24

Part A Cab

Length **48 mm** Width **32 mm** Thickness **26 mm**

Part B Hood

Length **32mm** Width **26 mm** Thickness **26 mm**

Part C Chassis

Length **104 mm** Width **32 mm** Thickness **13 mm**

Part D Trailer Mount

Length **48 mm** Width **14 mm** Thickness **14 mm**

Part E Wheel

Diameter **31 mm** Thickness **11 mm**

Part F Axle

Diameter **6mm** Length **60 mm**

Part G Hitch Pin

Diameter **6 mm** Length **17 mm**

Part H Axle Mount

Length **32 mm** Width **29 mm** Thickness **14 mm**

Part I Trailer Bed

Length **147 mm** Width **48 mm** Thickness **9 mm**

Part J Stake

Diameter **6 mm** Length **25 mm**

Logging Truck Reference Guide for Teachers

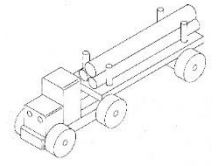

Section 6 Manufacturing

Page 27

If a hammer were to hit a nail incorrectly the nail may fly into or near the eyes. Dust and wood particles may also enter the eyes.

Page 30

Mark and cut sandpaper as in diagram to fit sanding blocks:

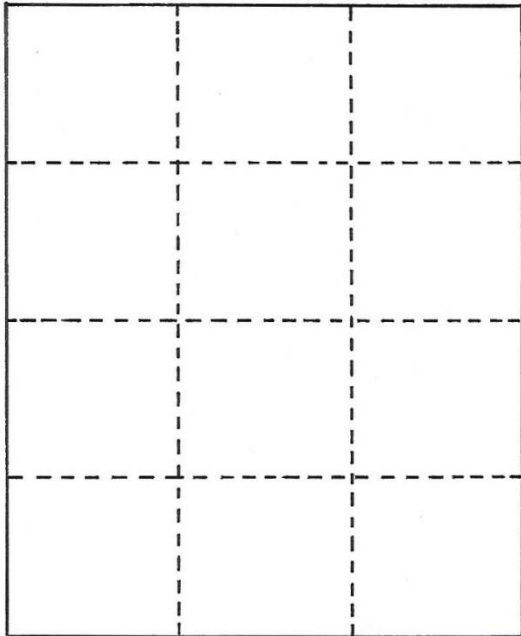

***NOTE TO TEACHER** – *Distribute sanding blocks and pre-cut coarse and medium sandpaper.*

Discuss different grits of sand with students. Larger grit is used first on rough wood; smaller grit is used for smooth finishing.

Page 39

NOTE TO TEACHER: *Have students hold branches securely while cutting. A clamp or a portable vise may be helpful. A hacksaw has very small teeth, making this a good choice for cutting the branches to length.*

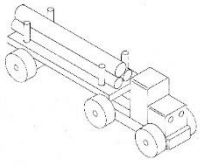

Logging Truck Reference Guide for Teachers

Section 8 Marketing

Page 45

Social Media, Web, Print, Digital, TV, Radio

Branding

Page 46

Coca Cola, Levis, Nike, Ford, Apple, iPhone

Pricing Worksheet

Page 48

	1 x 6 pine	\$ 24.00
	2 x 2 pine	4.00
	¼" dowel	12.00
	Paint	40.00
	Glue	20.00
		<hr/>
A	Total Material Cost	100.00
B	Total Labour Cost	400.00
C	Total Cost to Manufacture 100 units	500.00
D	Total Cost to Manufacture 1 unit	5.00
E	Add 100% Profit	5.00
F	Selling Price for Each Unit	<u>\$ 10.00</u>

Logging Truck Reference Guide for Teachers

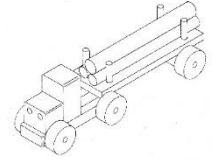

Section 9 Tree Harvesting

Traditional Aboriginal Perspectives and Knowledge of Tree Harvesting

Page 54

Logging Industry uses chainsaws, logging trucks and other heavy machinery to log mass areas for profit. The industry is regulated to protect the environment.

Traditional Aboriginal methods use handmade tools, fire and manpower to log selectively for individual needs. Spiritual and cultural values have always been and continue to be a principal consideration.

Section 10 Trades

Page 59

Tradespeople involved in building and maintaining logging trucks:

Welder, Metal Fabricator, Motor Vehicle Body Repairer, Automotive Painter, Diesel Engine Mechanic, Heavy Duty Equipment Technician, Transport Trailer Technician, Truck and Transport Mechanic

Name of trade being demonstrated in diagram:

Welding

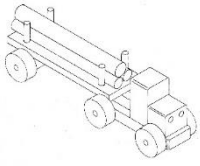

Logging Truck Reference Guide for Teachers

Page 60 Word Search

TRADES WORD SEARCH

E	C	T	X	E	R	V	K	C	C
C	I	S	B	H	O	Z	L	S	A
I	N	I	K	O	O	C	U	P	R
T	A	L	O	M	F	R	X	N	P
N	H	Y	J	E	E	E	S	W	E
E	C	T	L	P	R	B	K	K	N
R	E	S	N	I	A	M	A	R	T
P	M	R	I	D	Z	U	C	U	E
P	W	I	D	W	E	L	D	E	R
A	B	A	K	E	R	P	O	N	S
E	W	H	R	E	T	N	I	A	P

Page 62

* **NOTE TO TEACHER** – LINK to WorkBC website “Career Trek” for more detail on all trades: <http://www.careertrekbc.ca/episode/heavy-duty-equipment-mechanic> This is an excellent website provided by the Province of BC. Students may access information about different trades.

Design Challenge

Optional Lesson Enhancement

- Referring to the dump truck design lesson (Section 2 Page 5) have students build a prototype of their design using materials such as cardboard, wood, Styrofoam, dowels, etc. Buttons may be used to represent wheels.

Logging Truck Reference Guide for Teachers

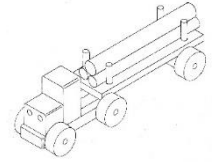

References

Stewart, H. (1984) *Cedar: Tree of Life to the Northwest Coast Indian*
Vancouver/Toronto: Douglas & McIntyre

Province of BC Ministry of Education New Curriculum Building Student
Success <https://curriculum.gov.bc.ca/>

Province of BC WorkBC Career Trek <http://www.careertrekbc.ca/>

Industry Training Authority <http://www.itabc.ca/>

Importance of Cedar. - SFU Museum of Archaeology and Ethnology
www.sfu.museum/time/en/videos/13/

Government of Canada – Indigenous Peoples and Forestry in Canada
<http://cfs.nrcan.gc.ca/pubwarehouse/pdfs/36704.pdf>

Aboriginal Perspectives and Knowledge content was reviewed by
Carrie Reid, Indigenous Education Resource Teacher

Illustrations by Peter Farkas, B.Ed. and Dale Schulz, DaschStudio